



GT5Y Series Miniature Electronic Timers

Four Selectable Operation Modes. Six Selectable Time Ranges. Delayed Output 4PDT/3A or DPDT/5A.

- Four operation modes: ON Delay, Interval ON, Cycle OFF, and Cycle ON
- Repeat error: $\pm 0.2\%$ ± 20 ms maximum
- Miniature size
- LED indicators for output and power
- Complies with safety standards. UL/c-UL listed. EN compliant.

Applicable Standards	Mark	File No. or Organization
UL508 CSA C22.2 No.14		UL/c-UL Listed File No. E55996
EN61812-1		EU Low Voltage Directive

Note: When using as a UL Listing approved product, use IDEC timer sockets under the below conditions.

SY4S-05*, SM2S-05* (Specify A, B, C, DF, DN, or U in place of *)

- Wire conductor temperature rating: 60°C min.
- Copper wire only: AWG14 max. (2mm² max.), AWG14 max. (0.9mm² max.)
- Tightening torque: 0.6 to 1.0N·m

SU4S-11L, SU2S-11L

- Wire conductor temperature rating: 60°C min.
- Copper wire only: AWG16 max. (solid wire 1.5mm² max., stranded wire 1.25mm² max.), AWG18 max. (0.9mm² max.)



Package Quantity: 1

(1) Operation Mode	Contact	Output	Time Ranges	Operating Voltage	Part No. (Ordering No.)			
A: ON Delay	DPDT	220V AC/ 30V DC, 5A	0.1S to 10H	100 to 120V AC	GT5Y-2SN1A100			
			0.1S to 30H		GT5Y-2SN3A100			
			0.1S to 60H		GT5Y-2SN6A100			
			B: Interval ON	DPDT	220V AC/ 30V DC, 5A	0.1S to 10H	200 to 240V AC	GT5Y-2SN1A200
						0.1S to 30H		GT5Y-2SN3A200
						0.1S to 10H		GT5Y-2SN1D12
C: Cycle OFF	DPDT	220V AC/ 30V DC, 5A				0.1S to 30H	12V DC	GT5Y-2SN3D12
						0.1S to 60H		GT5Y-2SN6D12
						0.1S to 10H		GT5Y-2SN1D24
			D: Cycle ON	4PDT	30V DC, 3A	0.1S to 30H	24V DC	GT5Y-2SN3D24
						0.1S to 60H		GT5Y-2SN6D24
						0.1S to 10H		GT5Y-4SN1A100
D: Cycle ON	4PDT	30V DC, 3A				0.1S to 30H	100 to 120V AC	GT5Y-4SN3A100
						0.1S to 60H		GT5Y-4SN6A100
						0.1S to 10H		GT5Y-4SN1A200
			D: Cycle ON	4PDT	30V DC, 3A	0.1S to 30H	200 to 240V AC	GT5Y-4SN3A200
						0.1S to 60H		GT5Y-4SN6A200
						0.1S to 10H		GT5Y-4SN1D12
D: Cycle ON	4PDT	30V DC, 3A				0.1S to 30H	12V DC	GT5Y-4SN3D12
						0.1S to 60H		GT5Y-4SN6D12
						0.1S to 10H		GT5Y-4SN1D24
			D: Cycle ON	4PDT	30V DC, 3A	0.1S to 30H	24V DC	GT5Y-4SN3D24
						0.1S to 60H		GT5Y-4SN6D24
						0.1S to 10H		GT5Y-4SN1D24

Note: S and M of the time range indicate second, and minute respectively.

Time Ranges

Code	Scale	(2) Time Range Indication	Time Range
1: 0.1S to 10H	0 to 1	1S	0.1 sec to 1 sec
		10S	0.2 sec to 10 sec
		1M	1 sec to 1 min
		10M	10 sec to 10 min
		1H	1 min to 1 hr
		10H	10 min to 10 hr
3: 0.1S to 30H	0 to 3	1S	0.1 sec to 3 sec
		10S	0.5 sec to 30 sec
		1M	3 sec to 3 min
		10M	30 sec to 30 min
		1H	3 min to 3 hr
		10H	30 min to 30 hr
6: 0.1S to 60H	0 to 6	1S	0.1 sec to 6 sec
		10S	1 sec to 60 sec
		1M	6 sec to 6 min
		10M	1 min to 60 min
		1H	6 min to 6 hr
		10H	60 min to 60 hr

Contact Ratings

Part No.	GT5Y-4	GT5Y-2
Contact Configuration	4PDT	DPDT
Rated Load	Resistive Load	220V AC, 3A/30V DC, 3A
	Inductive Load $\cos\theta=0.3, L/R=7ms$	220V AC, 0.8A/30V DC, 1.5A
Maximum Switching Voltage	250V AC/125V DC	250V AC/125V DC
Maximum Switching Current	3A	5A (Note)
Maximum Switching Frequency	1800 operations/hour	1800 operations/hour
Allowable Contact Power	Resistive Load	AC: 660VA/DC: 90W
	Inductive Load $\cos\theta=0.3, L/R=7ms$	AC: 176VA/DC: 45W
Minimum Applicable Load	5V DC, 10mA (reference value)	5V DC, 20mA (reference value)
	24V DC, 5mA (reference value)	24V DC, 10mA (reference value)
External Protection Element	Fuse 250V 3A	Fuse 250V 5A
Life	Electrical	200,000 operations minimum (220V AC, 3A)
	Mechanical	50 million operations minimum

Note: See Operating Temperature - Maximum Switching Current Characteristics.

Operating Temperature - Maximum Switching Current Characteristics

Check the derating curve described below when mounting more than two GT5Y-2 timers and SM2S-05* sockets.

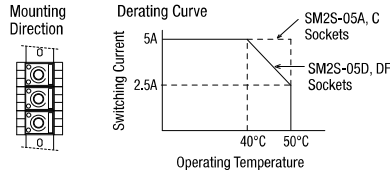

General Specifications

Model	GT5Y-□SN	
Operation	ON Delay / Interval ON / Cycle OFF / Cycle ON	
Pollution Degree	2 (IEC60664-1)	
Overvoltage Category	III (IEC60664-1)	
Rated Operational Voltage	A200	200 to 240V AC (50/60Hz)
	A100	100 to 120V AC (50/60Hz)
	D24	24V DC
	D12	12V DC
Voltage Range	A200	170 to 264V AC (50/60Hz)
	A100	85 to 132V AC (50/60Hz)
	D24	21.6 to 26.4V DC
	D12	10.8 to 13.2V DC
Reset Voltage	Rated Voltage × 20% minimum	
Operating Temperature	-10 to +50°C (no freezing and condensation)	
Storage/Transportation Temperature	-30 to +80°C (no freezing and condensation)	
Operating Humidity	35 to 85% RH (no condensation)	
Storage Humidity	35 to 85% RH (no condensation)	
Altitude	0 to 2000m (operation), 0 to 3000m (transportation)	
Reset Time	100 ms maximum	
Repeat Error	Within ±0.2%, ±20 ms	
Voltage Error	Within ±0.5%, ±20 ms	
Temperature Error	±3%	
Setting Error	±10%	
Insulation Resistance	100 MΩ minimum (500V DC megger)	
Dielectric Strength	Between power and output terminals: 2000V AC, 1 minute	
	Between contacts of different poles: 2000V AC, 1 minute	
	Between contacts of the same pole: 1000V AC, 1 minute	
Vibration Resistance	Operating extremes: 10 to 55 Hz, amplitude 0.5 mm, 10 minutes each in 3 directions	
	Damage limits: 10 to 55 Hz, amplitude 0.75 mm, 2 hours each in 3 directions	
Shock Resistance	Operating extremes: 98 m/s ² , Damage limits: 490 m/s ² , 3 shocks each in 6 directions	
	Degree of Protection IP40 (timer), IP20 (socket) (IEC60529)	
Power Consumption (approx.)	A200	1.2 VA (200V AC/60Hz), 1.2 VA (200V AC/50Hz)
	A100	1.1 VA (100V AC/60Hz), 1.2 VA (100V AC/50Hz)
	D24	1.0W
	D12	0.9W
Dimensions	27.7H × 21.0W × 58.3D mm	
Weight (approx.)	42g	

Note: See Operating Temperature – Maximum Switching Current Characteristics.

Operation Charts and Internal Connections

Operation Mode	Item	Operation
A: ON Delay	Terminal No. 13-14 (POWER)	Set Time
	1-9, 2-10, 3-11, 4-12 (NC)	
	5-9, 6-10, 7-11, 8-12 (NO)	
	POWER Indicator	
	OUT Indicator	
B: Interval ON	Terminal No. 13-14 (POWER)	Set Time
	1-9, 2-10, 3-11, 4-12 (NC)	
	5-9, 6-10, 7-11, 8-12 (NO)	
	POWER Indicator	
	OUT Indicator	
C: Cycle OFF	Terminal No. 13-14 (POWER)	Set Time
	1-9, 2-10, 3-11, 4-12 (NC)	
	5-9, 6-10, 7-11, 8-12 (NO)	
	POWER Indicator	
	OUT Indicator	
D: Cycle ON	Terminal No. 13-14 (POWER)	Set Time
	1-9, 2-10, 3-11, 4-12 (NC)	
	5-9, 6-10, 7-11, 8-12 (NO)	
	POWER Indicator	
	OUT Indicator	

(Internal Connections)

- GT5Y-4
- GT5Y-2

Electrical Life Curves

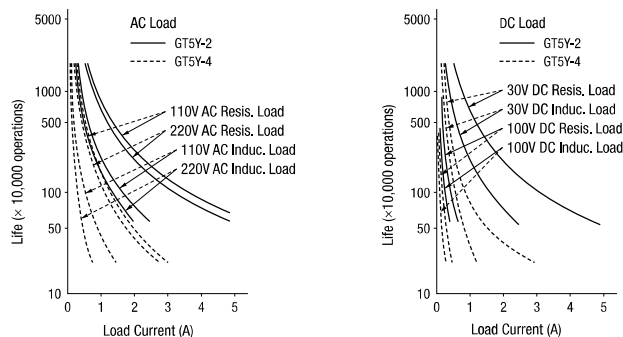

Dimensions

All dimensions in mm.

(When using DIN Rail Mount Socket)

GT5Y-4

See Relay Sockets catalog for SY4S-05B, SY4S-05C, SY4S-05D, SY4S-05DF.

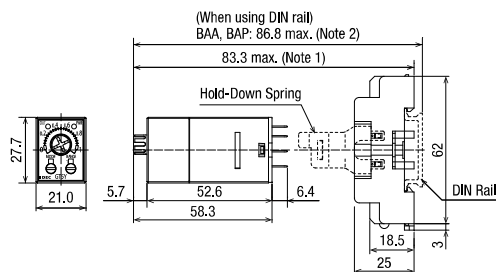

Note 1: SY4S-05B: 83.3 max., SY4S-05C: 83.3 max., SY4S-05D: 88.3 max., SY4S-05DF: 88.3 max.
 Note 2: SY4S-05B: 86.8 max., SY4S-05C: 86.8 max., SY4S-05D: 91.8 max., SY4S-05DF: 91.8 max.

GT5Y-2

See Relay Sockets catalog for SM2S-05B, SM2S-05C, SM2S-05D, SM2S-05DF.

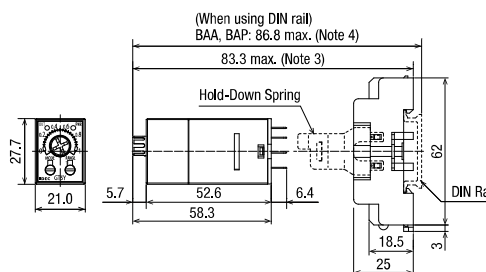

Note 3: SM2S-05B: 83.3 max., SM2S-05C: 83.3 max., SM2S-05D: 88.3 max., SM2S-05DF: 88.3 max.
 Note 4: SM2S-05B: 86.8 max., SM2S-05C: 86.8 max., SM2S-05D: 91.8 max., SM2S-05DF: 91.8 max.

GT5Y-4 and SU4S-11L, GT5Y-2 and SU2S-11L

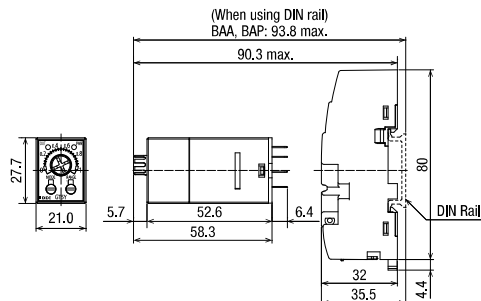

Applicable hold-down spring: SFA-202

Accessories

Accessories

Both SY4S-05B, SY4S-05C, SY2S-05B, SM2S-05B, and SM2S-05C are UL recognized, CSA certified, and TÜV approved. Others are UL recognized and CSA certified, except for SY4S-05A and SM2S-05A.



When ordering, specify the Ordering No.

Item	Part No.	Ordering No.	Package Quantity	Remarks	
DIN Rail Mount Socket	Socket	SY4S-05B	SY4S-05A	1	For 4PDT contact (Screw)
		SY4S-05C	SY4S-05C	1	For 4PDT contact (Screw)
		SY4S-05DF	SY4S-05DF	1	For 4PDT contact (Screw)
		SU2S-21L	SU2S-21L	1	For DPDT contact (Push-in)
	Hold-Down Spring	SU4S-21L	SU4S-21L	1	For 4PDT contact (Push-in)
		SM2S-05B	SM2S-05A	1	For DPDT contact (Screw)
		SM2S-05C	SM2S-05C	1	For DPDT contact (Screw)
		SM2S-05DF	SM2S-05DF	1	For DPDT contact (Screw)
Panel/PC Board Mount Socket	Socket	SFA-202	SFA-202PN20	10 sets (20 pcs)	For SY4S-05A, SM2S-05A (2 pcs/set)
		SFA-511	SFA-511PN20	20	For SY4S-05D, SY4S-05DF, SM2S-05D, SM2S-05DF
		SU9Z-S21T	SU9Z-S21T	10	For SU2S-21L, SU4S-21L
		SY4S-51	SY4S-51	1	For 4DPT contact, Solder Terminal
	Hold-Down Spring	SY4S-61	SY4S-61	1	For 4DPT contact, PC Board Terminal
SM2S-51		SM2S-51	1	For DPDT contact, Solder Terminal	
		SM2S-61	SM2S-61	1	For DPDT contact, PC Board Terminal
	SFA-302	SFA-302PN20	10 sets (20 pcs)	For SY4S-51, SY4S-61, SM2S-51, SM2S-61 (2 pcs/set)	

GT5P Series Miniature Electronic Timers

Economic Efficiency Focused Delayed Output SPDT/5A

- Three operation modes: ON Delay, Cycle, and One Shot
- Repeat error: $\pm 0.2\% \pm 10$ ms maximum
- Complies with safety standards
UL recognized, CSA certified, TÜV approved, EN compliant

Applicable Standards	Mark	File No. or Organization
UL508		UL/c-UL recognized File No. E55996
CSA C22.2 No.14		CSA File No. LR66809
EN61812-1		EU Low Voltage Directive



Package Quantity: 1

Operation Mode	Contact	Output	Time Range	Operating Voltage	Part No. (Ordering No.)			
ON Delay	SPDT	24V DC/ 120V AC, 5A 240V AC, 3A	3S	100 to 120V AC	GT5P-N3SA100			
			10S		GT5P-N10SA100			
			30S		GT5P-N30SA100			
			60S		GT5P-N60SA100			
			3M		GT5P-N3MA100			
			6M		GT5P-N6MA100			
			10M		GT5P-N10MA100			
			1S		200 to 240V AC	GT5P-N1SA200		
			6S			GT5P-N6SA200		
			10S			GT5P-N10SA200		
			30S	GT5P-N30SA200				
			60S	GT5P-N60SA200				
			3M	GT5P-N3MA200				
			6M	GT5P-N6MA200				
			10M	GT5P-N10MA200				
			1S	24V AC/DC		GT5P-N1SAD24		
			6S			GT5P-N6SAD24		
			10S		GT5P-N10SAD24			
			60S		GT5P-N60SAD24			
			6M		GT5P-N6MAD24			
10M	GT5P-N10MAD24							
10S	12V DC	GT5P-N10SD12						
30S		GT5P-N30SD12						
60S		GT5P-N60SD12						
10M		GT5P-N10MD12						
Cycle	SPDT	24V DC/ 120V AC, 5A 240V AC, 3A	3S	100 to 120V AC	GT5P-F3SA100			
			10S	100 to 120V AC	GT5P-F10SA100			
			3S	200 to 240V AC	GT5P-F3SA200			
			10S	200 to 240V AC	GT5P-F10SA200			
			3S	24V AC/DC	GT5P-F3SAD24			
			10S	24V AC/DC	GT5P-F10SAD24			
			3S	12V DC	GT5P-F3SD12			
			10S	12V DC	GT5P-F10SD12			
			One Shot	SPDT	24V DC/ 120V AC, 5A 240V AC, 3A	3S	100 to 120V AC	GT5P-P3SA100
						3S	200 to 240V AC	GT5P-P3SA200
10S	200 to 240V AC	GT5P-P10SA200						
3S	24V AC/DC	GT5P-P3SAD24						
10S	24V AC/DC	GT5P-P10SAD24						

Note: S and M of time range indicate second and minute respectively.

Time Ranges

Code	Time Range
1S	0.1 sec to 1 sec
3S	0.1 sec to 3 sec
6S	0.1 sec to 6 sec
10S	0.2 sec to 10 sec
30S	0.5 sec to 30 sec
60S	1 sec to 60 sec
3M	3 sec to 3 min
6M	6 sec to 6 min
10M	10 sec to 10 min

Contact Ratings

Contact Configuration		SPDT
Maximum Switching Voltage		250V AC, 150V DC
Maximum Switching Current		5A
Maximum Switching Power		AC: 960VA DC: 120W
Rated Load	Resistive Load	120V AC / 24V DC, 5A 240V AC, 3A
	Inductive Load $\cos\phi = 0.4$ L/R = 15 ms	240V AC, 0.8A 120V AC, 1.4A 24V DC, 1.7A
Life	Electrical	100,000 operations minimum (rated resistive load)
	Mechanical	20,000,000 operations minimum

Minimum Applicable Load: 5V DC 10 mA (reference value)

General Specifications

Model	GT5P-N	GT5P-F	GT5P-P
Operation	ON Delay	Cycle	One Shot
Pollution Degree	2 (IEC60664-1)		
Rated Operational Voltage	A200	200 to 240V AC (50/60Hz)	
	A100	100 to 120V AC (50/60Hz)	
	AD24	24V AC (50Hz/60Hz)/24V DC	
	D12	12V DC	
Voltage Range	A200	170 to 264V AC (50/60Hz)	
	A100	85 to 132V AC (50/60Hz)	
	AD24	20.4 to 26.4V AC (50/60Hz)/21.6 to 26.4V DC	
	D12	10.8 to 13.2V DC	
Operating Temperature	-10 to +50°C (no freezing)		
Storage Temperature	-30 to +70°C (no freezing)		
Operating Humidity	35 to 85% RH (no condensation)		
Storage Humidity	30 to 85% RH (no condensation)		
Altitude	0 to 2000m (operation), 0 to 3000m (transportation)		
Reset Time	100 ms maximum		
Repeat Error	±0.2%, ±10 ms		
Voltage Error	±0.5%, ±20 ms		
Temperature Error	±3%		
Setting Error	±10%		
Insulation Resistance	100 MΩ minimum (500V DC megger)		
Dielectric Strength	Between power and output terminals: 2000V AC, 1 minute		
	Between contacts of different poles: 2000V AC, 1 minute		
	Between contacts of the same pole: 750V AC, 1 minute		
Vibration Resistance	Operating extremes: 10 to 55Hz, amplitude 0.75 mm, 10 minutes each in 3 directions		
	Damage limits: 10 to 55Hz, amplitude 0.75 mm, 2 hours each in 3 directions		
Shock Resistance	Operating extremes: 98 m/s ² , Damage limits: 490 m/s ²		
Power Consumption (approx.)	A200	5.0 VA (60Hz)	5.0 VA (60Hz)
	A100	2.9 VA (60Hz)	2.9 VA (60Hz)
	AD24	1.4 VA (60Hz)/0.5W	1.4 VA (60Hz)/0.5W
	D12	0.6W	0.6W
Dimensions	36H × 29W × 81.5D mm		
Weight (approx.)	54g		

Electrical Life Curves

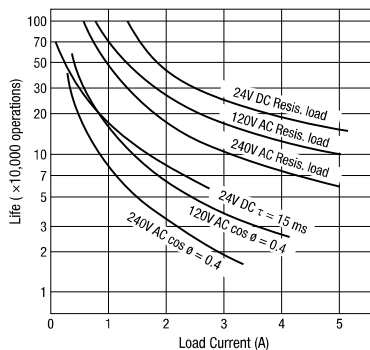

Operation Charts and Internal Connections

Operation Mode	Item	Operation
On Delay	Terminal No. 2-7 (POWER)	[Timing diagram showing power pulse with 'Set Time' interval]
	5-8 (NC)	[Timing diagram showing normally closed contact state]
	6-8 (NO)	[Timing diagram showing normally open contact state]
	POWER Indicator	[Timing diagram showing indicator pulse]
	OUT Indicator	[Timing diagram showing output pulse]
Cycle	Terminal No. 2-7 (POWER)	[Timing diagram showing power pulse with 'Set Time' and 'T' intervals]
	5-8 (NC)	[Timing diagram showing normally closed contact state]
	6-8 (NO)	[Timing diagram showing normally open contact state]
	POWER Indicator	[Timing diagram showing indicator pulse]
	OUT Indicator	[Timing diagram showing output pulse]
One Shot	Terminal No. 13-14 (POWER)	[Timing diagram showing power pulse]
	3-4 (Start Input)	[Timing diagram showing start input pulse with '50ms minimum' interval]
	5-8 (NC)	[Timing diagram showing normally closed contact state]
	6-8 (NO)	[Timing diagram showing normally open contact state]
	OUT Indicator	[Timing diagram showing output pulse]

(Internal Connections)

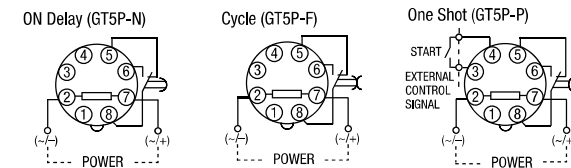

Dimensions

All dimensions in mm.

(When using DIN Rail Mount Socket)

SR2P-05B

For SR2P-05C, see Relay Sockets catalog.

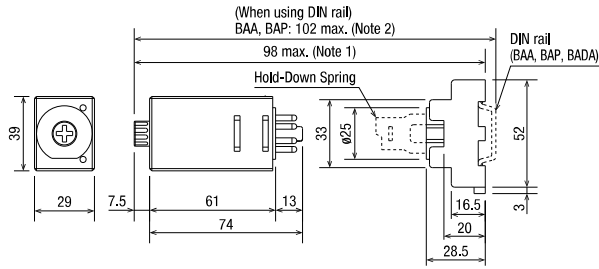

SR2P-06B

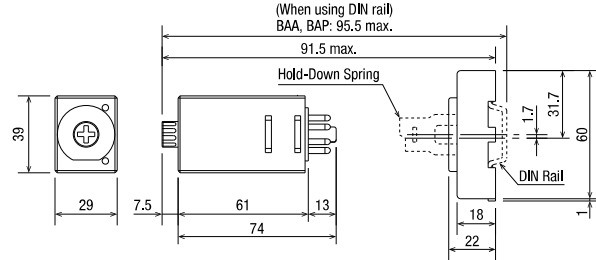

Note 1: SR2P-05C: 99.5 max.

Note 2: SR2P-05C: 103.5 max.

Mounting Hole Layout (for Panel/PC Board Mount Socket)

1. GT5Y-4

Panel Mount Socket (SY4S-51)

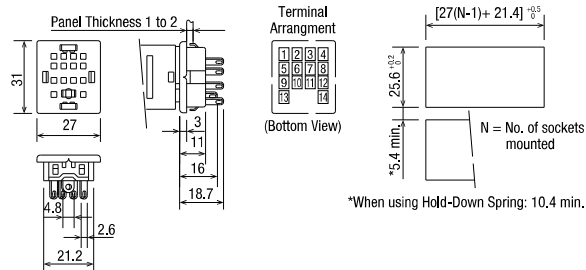

*When using Hold-Down Spring: 10.4 min.

2. GT5Y-2

Panel Mount Socket (SM2S-51)

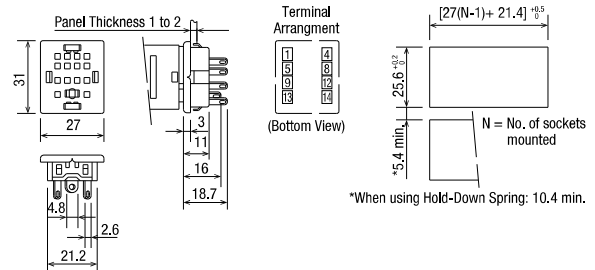

*When using Hold-Down Spring: 10.4 min.

PC Board Mount Socket (SY4S-61)

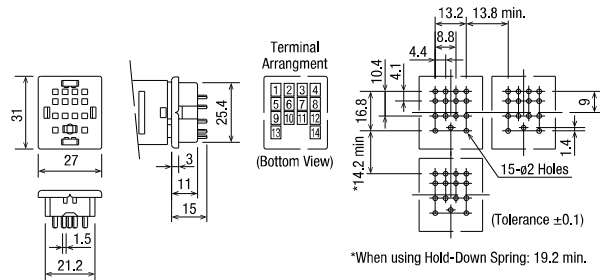

*When using Hold-Down Spring: 19.2 min.

PC Board Mount Socket (SM2S-61)

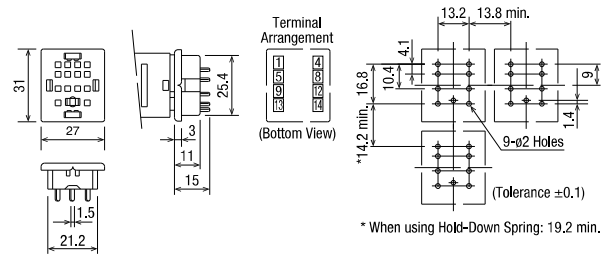

*When using Hold-Down Spring: 19.2 min.

3. GT5P

Solder Terminal (SR2P-511)

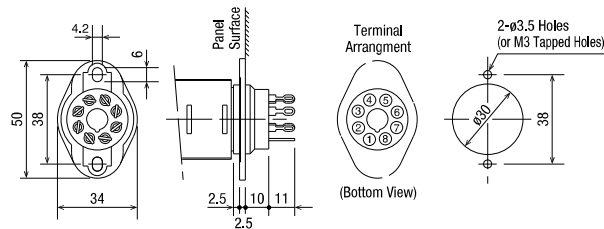

Wire Wrap Terminal (SR2P-70)

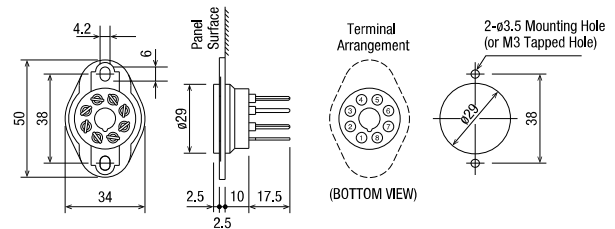

Accessories

Item	Part No.	Ordering No.	Package Quantity	Remarks	
DIN Rail Mount Socket	Socket	SR2P-06B	SR2P-06B	1	
		SR2P-05B	SR2P-05B	1	
		SR2P-05C	SR2P-05C	1	UL/CSA/TÜV
	Hold-Down Spring	SFA-202	SFA-202PN20	10 sets (20 pcs)	For SR2P-06A (2 pcs/set)
		SFA-203	SFA-203PN20	10 sets (20 pcs)	For SR2P-05A (2 pcs/set)
Panel Mount Socket	w/Solder Terminals	SR2P-511	SR2P-511	1	UL/CSA
	w/Wire Wrap Terminals	SR2P-70	SR2P-70	1	

Installation of Hold-Down Springs

DIN Rail Mount Socket

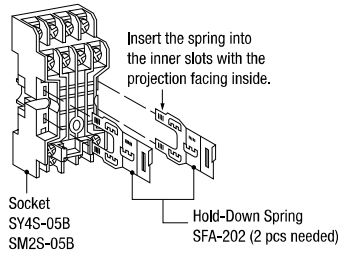

Recommended Tightening Torque and Terminal Screw

Timer	Applicable Socket	Terminal Screw	Recommended Tightening Torque
GT5Y	SY4S-05 SM2S-05	M3	0.6 to 1.0 N·m

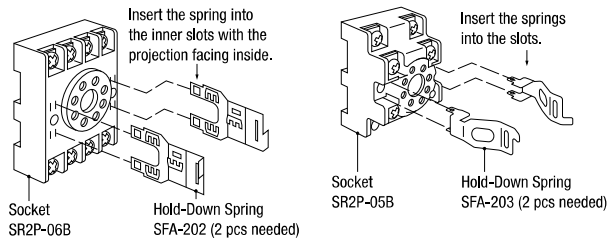

Note 1: Once installed into sockets, the hold-down springs cannot be removed.
 Note 2: Hold-down springs cannot be used on SR2P-511 for GT5P.

Recommended Tightening Torque and Terminal Screw

Timer	Applicable Socket	Terminal Screw	Recommended Tightening Torque
GT5P	SR2P-05 SR2P-06	M3.5	1.0 to 1.3 N·m

Panel/PC Board Mount Socket

The SFA-302 Hold-Down Springs can be installed to the SY4S-51, SY4S-61, SM2S-51, and SM2S-61 sockets.

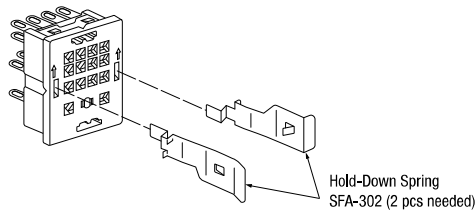

Hold-down springs cannot be installed to SR2P-511 and SR2P-70 panel mount sockets.

Installation/Removal of Hold-Down Springs

(Installation)

Insert the hold-down springs (SFA-511) into mounting holes 1 and 2 with the projection facing outside.

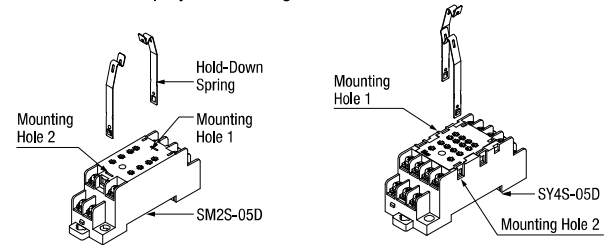

(Removal)

Press the projections of Hold-Down Springs (SFA-511) in the direction shown in the arrow and pull upward to remove.

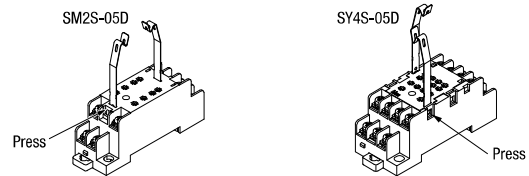

Installation/Removal of Hold-Down Springs

(Installation)

Insert the springs (SFA-511) into mounting holes 1 and 2 with the projection facing outside.

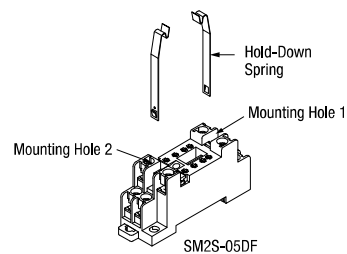

(Removal)

Press the projections of Hold-Down Springs (SFA-511) in the direction shown in the arrow and pull upward to remove.

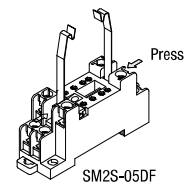

Note: Apply the same method to SY4S-05DF.

⚠ Safety Precautions

- Be sure to turn off power before mounting, removal, wiring, maintenance and inspection. Otherwise, electric shock or fire could occur.
- Be sure to use wires to meet voltage and current requirements and tighten M3.5 terminal screws to a tightening torque of 1.0 to 1.3 N·m. Be sure to solder the terminals correctly. Loose terminal screws or incomplete soldering may cause abnormal heat and fire.

Instructions

Time Range Setting

The time range is calibrated at its maximum time scale, therefore it is desirable to use the timer at a setting as close to its maximum time scale as possible for accurate time delay. For a more accurate time delay, adjust the control knob by measuring the operating time with a watch before application.

On the GT5Y timers, a desired time range can be selected using the time range selectors on the side surface. Turn the multiplier and time unit selectors using a flat screwdriver until they click.

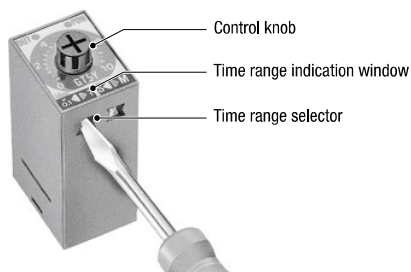

Timing Accuracy

Timing accuracies are calculated from the following formulas:

Repeat Error

$$= \pm \frac{1}{2} \times \frac{\text{Max. measured value} - \text{Min. measured value}}{\text{Maximum scale value}} \times 100 (\%)$$

Voltage Error

$$= \pm \frac{T_v - T_r}{T_r} \times 100 (\%)$$

T_v : Average of measured values at voltage V
 T_r : Average of measured values at the rated voltage

Temperature Error

$$= \pm \frac{T_t - T_{20}}{T_{20}} \times 100 (\%)$$

T_t : Average of measured values at $t^\circ\text{C}$
 T_{20} : Average of measured values at 20°C

Setting Error

$$= \frac{\text{Average of measured values} - \text{Set value}}{\text{Maximum scale value}} \times 100 (\%)$$

Use of External Input (GT5P-P Only)

1. Do not apply voltage to external input terminals 3 and 4. Be sure not to connect external inputs to other terminals because the internal circuit may be damaged.
2. Use reliable mechanical contacts capable of switching approximately 22V DC, 1 mA to close input terminals 3 and 4. (Closed: 1 k Ω maximum, Open: 100 k Ω minimum) The input terminals should not be connected to a ground wire of other devices.
3. Do not install input lines in parallel with high-voltage or motor lines. Use shielded wires or separate conduit for input lines, and make the input lines as short as possible.

Load Current

The rated current of the contact (or control output) should not be exceeded. Especially for inductive, capacitive, and incandescent lamp loads, the inrush current as large as a few to several tens times the rated current may cause welded contacts and other troubles. The amount of inrush current as well as steady-state current must be taken into consideration.

Contact Protection

Switching an inductive load generates a counter-electromotive force in the coil. The counter emf will cause arcing, which may shorten the contact life. Application of a protection circuit is recommended for contact protection.

Rest Time

When turning power off after time-out, allow a rest time of 0.1 sec, and during operation, 1 sec at least.

Power

Since DC types are designed to operate on DC power containing 10% or less ripple, insert a smoothing circuit when using a rectified AC power to operate DC type timers.

Continuous Energizing

Continuous energizing for a long period of time may damage the electrical characteristics of the timer because of internal heating. Use an additional relay to the output circuit and refrain from continuous energizing of the timer.

Dielectric Strength Test

When performing an insulation resistance or dielectric strength test on control panels containing timers, make sure that the dielectric strength of the timer is not exceeded. In case the dielectric strength is exceeded, remove the timers from the panels.

Operating Environment

Temperature and Humidity

Use the timer within the operating temperature and operating humidity ranges and prevent freezing and condensation. After storing below the operation temperature, leave the timer at room temperature for a sufficient period of time before use.

Environment

Prevent a corrosive gas such as sulfurous or ammonia gas, organic solvents (alcohol, benzene, thinner, etc.), strong alkaline substances or strong acids from touching to the timer, and do not use the timer in such an environment. Keep the timer from water splashes or steam.

Vibration and Shock

Since excessive vibrations or shocks cause the output contacts to open, the timer should be used within the operating extremes of vibration and shock resistance. Use of hold-down springs is recommended for secure mounting on sockets.

Others

- Use a mechanical-contact switch or relay to supply power to the time.
- When driving the timer using a solid-state output device such as two-wire proximity switch, photoelectric switch or solid-state relay directly, malfunction may be caused by a leakage current from the solid-state device. Be sure to check thoroughly before using.
- Since AC types (such as A100 and A200) comprise a capacitive load, the SSR dielectric strength should be two or more times as large as the power voltage when switching the timer power using an SSR.
- To make a sequence circuit by connecting timer and relay, check the timer operation sufficiently in consideration of the reset time of the timer.

GE1A Series Electronic Timers

Two different time ranges to cover a wide time range

- Large clear knob for easy time range setting
- ON Delay function
- Highly precise time control
- Instant monitoring of operation status by LED indicators.

Applicable Standards	Mark	File No. or Organization
UL508 CSA C22.2 No. 14		UL/c-UL Listed File No. E204716
EN61812-1		EU Low Voltage Directive
		TÜV Product Service



Contact Ratings

Contact Ratings	240V AC/5A, 24V DC/5A (resistive load)
Electrical Life	100,000 operations minimum (resistive load)
Mechanical Life	GE1A-B: 10,00,000 operations minimum GE1A-C: 5,000,000 operations minimum

10H



30H



Time Ranges

Time Range Code	Magnification	Time Range
10H	1S	0.1 sec. to 1 sec.
	10S	1 sec. to 10 sec.
	1M	0.1 min. to 1 min.
	10M	1 min. to 10 min.
	1H	0.1 hour to 1 hour
30H	10H	1 hour to 10 hours
	1S	0.3 sec. to 3 sec.
	10S	3 sec. to 30 sec.
	1M	0.3 min. to 3 min.
	10M	3 min. to 30 min.
1H	0.3 hour to 3 hour	
10H	3 hour to 30 hours	

Time Range	Rated Voltage	Part No.	
		Contact	
		Delayed SPDT + Instantaneous SPDT	Delayed DPDT
10H (0.1 sec. to 10 hours)	220 to 240V AC	GE1A-B10HA220	GE1A-C10HA220
	200 to 220V AC	GE1A-B10HA200	GE1A-C10HA200
	110 to 120V AC	GE1A-B10HA110	GE1A-C10HA110
	100 to 110V AC	GE1A-B10HA100	GE1A-C10HA100
	24V AC/DC	GE1A-B10HAD24	GE1A-C10HAD24
30H (0.3 sec. to 30 hours)	220 to 240V AC	GE1A-B30HA220	GE1A-C30HA220
	200 to 220V AC	GE1A-B30HA200	GE1A-C30HA200
	110 to 120V AC	GE1A-B30HA110	GE1A-C30HA110
	100 to 110V AC	GE1A-B30HA100	GE1A-C30HA100
	24V AC/DC	GE1A-B30HAD24	GE1A-C30HAD24

Part No. Development

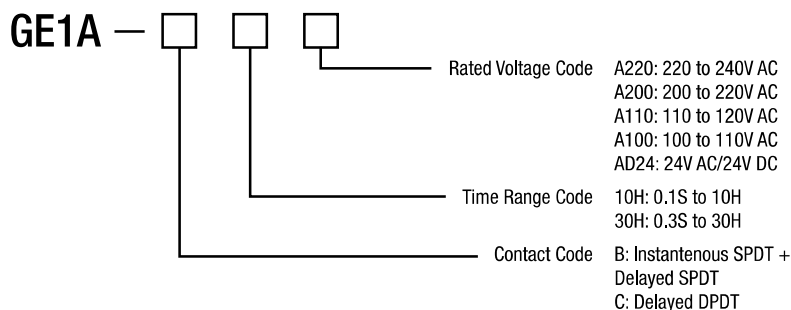

Specifications

Model		GE1A-B	GE1A-C
Operation Mode		ON Delay	
Time Range		0.1 second to 30 hours	
Rated Operational Voltage		220V to 240V AC, 200 to 220V AC, 110V to 120V AC, 100 to 110V AC, 24V AC/DC	
Voltage Tolerance		AC: 85 to 110%, DC: 90 to 110%	
Operating Temperature		-10 to +55°C (without freezing)	
Storage Temperature		-30 to +70°C (without freezing)	
Operating Humidity		35 to 85% RH (without condensation)	
Repeat Error		±0.2% ±10 ms maximum	
Voltage Error		±0.5% ±10 ms maximum	
Temperature Error		±3% maximum	
Setting Error		±10% maximum	
Insulation Resistance		100 MΩ minimum (500V DC megger)	
Dielectric Strength	Between power and output terminals	2,000V AC, 1 minute	
	Between contact circuits	750V AC, 1 minute	
	Between contact circuits (opposite pole)	2,000V AC, 1 minute	
Vibration Resistance		Damage limits: Amplitude 0.75 mm, 10 to 55 Hz Operating extremes: Amplitude 0.5 mm, 10 to 55 Hz	
Shock Resistance	Damage limits	Panel mount: 490 m/s ² (approx. 50G) Surface mount: 249 m/s ² (approx. 25G)	
	Operating extremes	98 m/s ² (approx. 10G)	
Power Consumption	220V AC	7.7 VA (60 Hz), 6.6 VA (50 Hz)	8.0 VA (60 Hz), 7.0 VA (50 Hz)
	200V AC	7.0 VA (60 Hz), 6.0 VA (50 Hz)	8.0 VA (60 Hz), 7.0 VA (50 Hz)
	110V AC	3.8 VA (60 Hz), 3.3 VA (50 Hz)	3.5 VA (60 Hz), 3.0 VA (50 Hz)
	100V AC	3.5 VA (60 Hz), 3.0 VA (50 Hz)	3.5 VA (60 Hz), 3.0 VA (50 Hz)
	24V AC	1.6 VA	2.0 VA
	24V DC	1.0W	0.8W
Weight (Approx.)		101g	95g

GE1A-B

Item	Terminal No.	Operation
Power	2-7 (Power)	
Delayed Contact	5-8 (NC)	
	6-8 (NO)	
Instantaneous Contact	1-4 (NC)	
	1-3 (NO)	
LED Indicator	POWER	
	OUT	

GE1A-C

Item	Terminal No.	Operation
Power	2-7 (Power)	
Delayed Contact	1-4, 5-8 (NC)	
	1-3, 6-8 (NO)	
LED Indicator	POWER	
	OUT	

Internal Connections

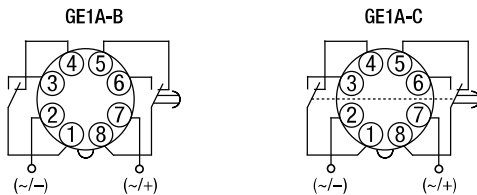

Dimensions

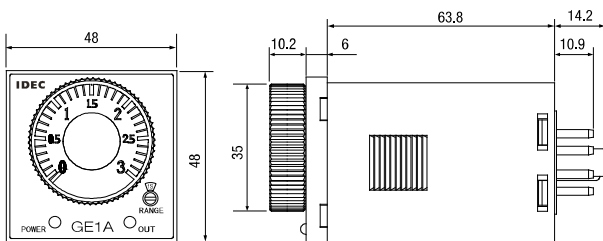

Panel Cut-out

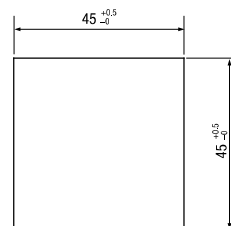

Applicable Sockets

All dimensions in mm.

SR2P-05B (not UL/c-UL listed)

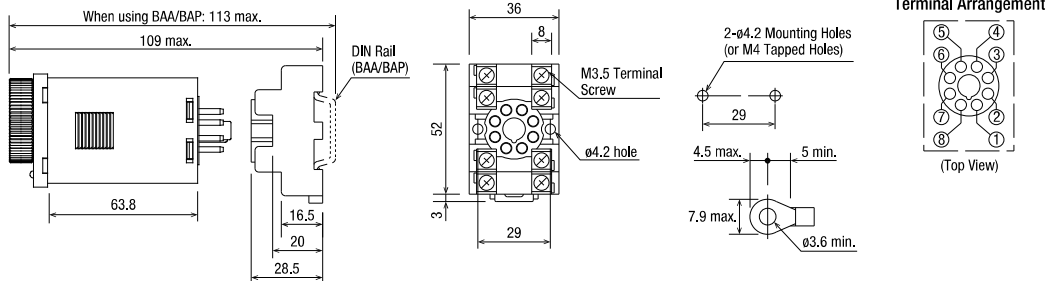

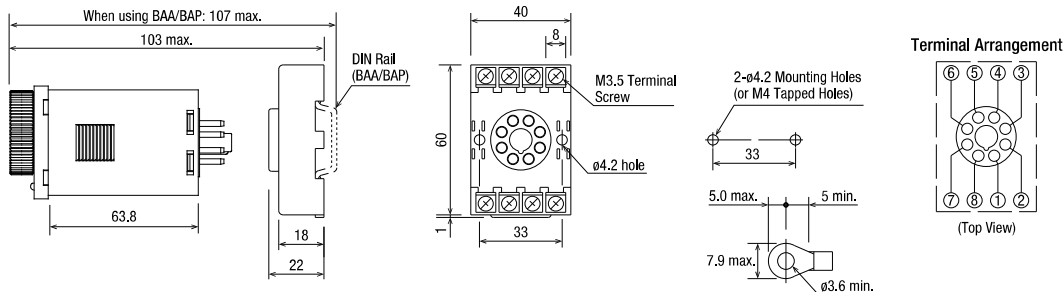

SR2P-06B

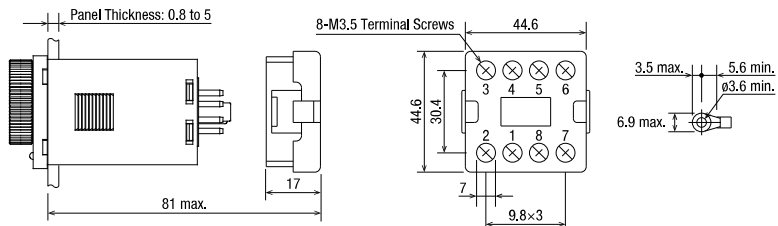

SR6P-M08G



Accessories

Name	Shape	Part No.
Panel Mount Adapter		GE9Z-AD
Dust Cover		GE9Z-C48

IDEC CORPORATION

 www.idec.com

Head Office

6-64, Nishi-Miyahara-2-Chome, Yodogawa-ku, Osaka 532-0004, Japan

USA	IDEC Corporation	Tel: +1-408-747-0550	opencontact@idec.com	Taiwan	IDEC Taiwan Corporation	Tel: +886-2-2577-6938	service@tw.idec.com
Germany	APEM GmbH	Tel: +49-40-25 30 54-0	service@eu.idec.com	Hong Kong	IDEC Izumi (H.K.) Co., Ltd.	Tel: +852-2803-8989	info@hk.idec.com
Singapore	IDEC Izumi Asia Pte. Ltd.	Tel: +65-6746-1155	info@sg.idec.com	China/Shanghai	IDEC (Shanghai) Corporation	Tel: +86-21-6135-1515	idec@cn.idec.com
Thailand	IDEC Asia (Thailand) Co., Ltd	Tel: +66-2-392-9765	sales@th.idec.com	China/Shenzhen	IDEC (Shenzhen) Corporation	Tel: +86-755-8356-2977	idec@cn.idec.com
Australia	IDEC Australia Pty, Ltd.	Tel: +61-3-8523-5900	sales@au.idec.com	China/Beijing	IDEC (Beijing) Corporation	Tel: +86-10-6581-6131	idec@cn.idec.com
India	IDEC Controls India Private Limited	Tel: +91-80679-35328	info_india@idec.com	Japan	IDEC Corporation	Tel: +81-6-6398-2527	marketing@idec.co.jp

Specifications and other descriptions in this brochure are subject to change without notice.

Information in this brochure is current as of June, 2020.

2020 IDEC Corporation, All Rights Reserved.

EP1438-12

